

Sage Model Notes

LoudspeakerVoicecoil.stl

D. Gedeon
24 June 2012

A model of a voice-coil type linear actuator commonly used for driving loudspeakers. A circular coil moves axially back and forth within a radial magnetic field between inner and outer pole pieces. The coil moves parallel to the pole faces in the direction shown by the red arrow. The magnets produce a magnetic field in the direction of the green arrows which turns radially in the gap between pole pieces:

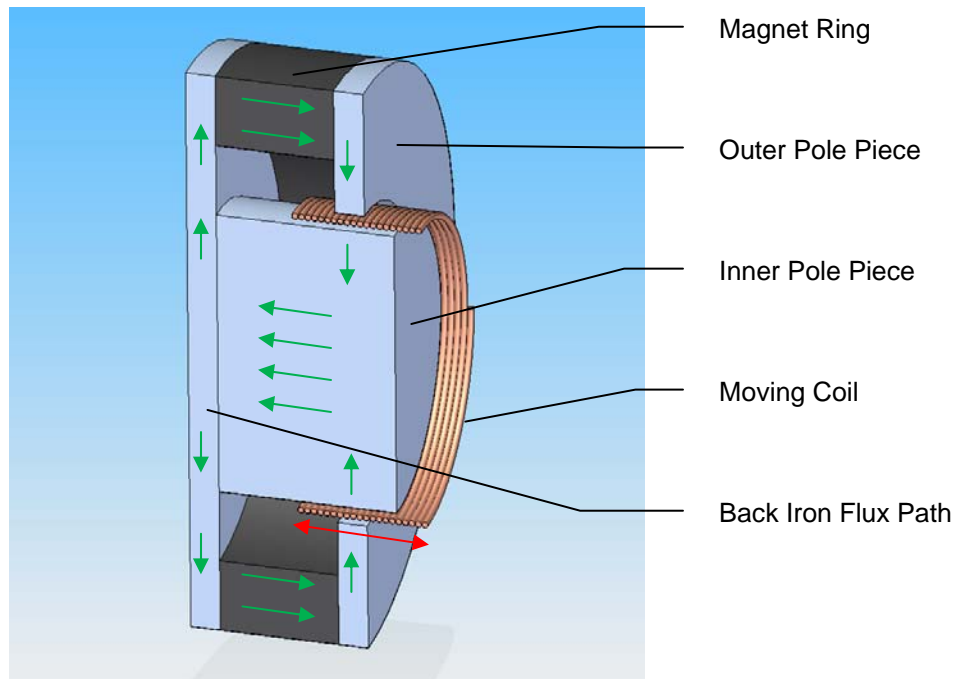

The voice coil is longer than the air gap so that it remains entirely within the gap during normal operation and produces a linear variation of actuator force with electrical current, independent of coil position. The speaker cone attached to the coil and outer structure that holds everything in alignment is not shown.

The Sage root model looks like this:

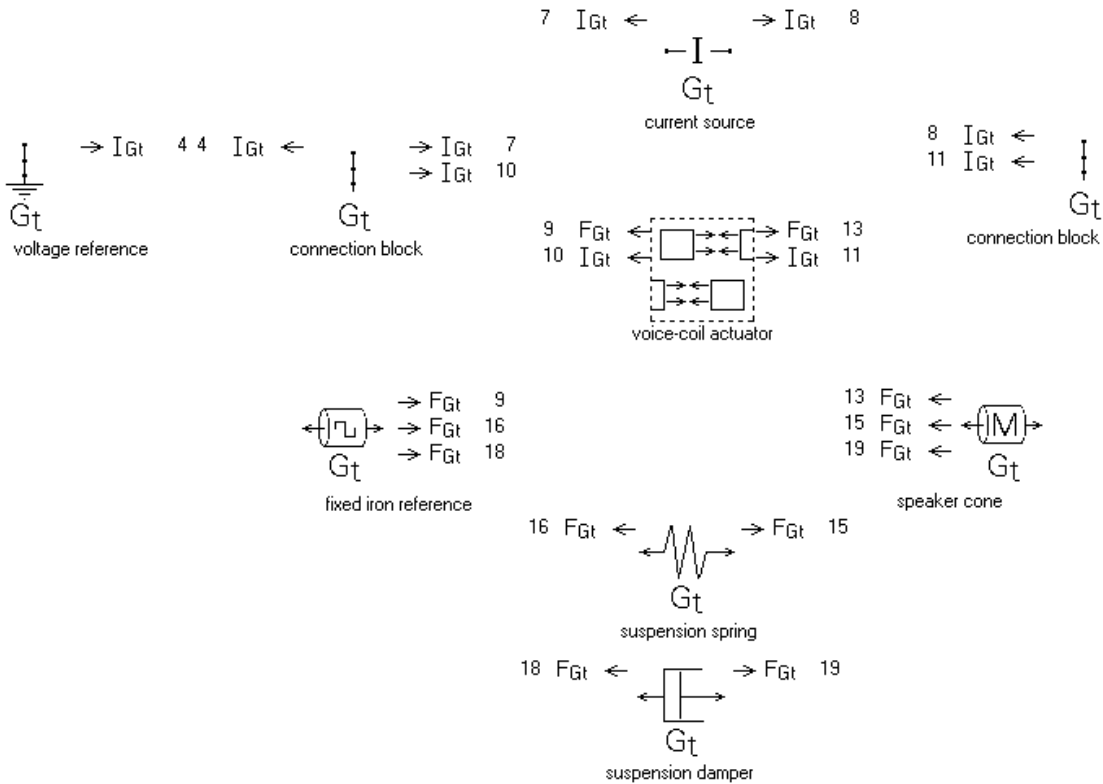

A *current source* (top row) drives electrical current through the coil within the *voice-coil actuator* submodel. A constrained piston *fixed iron reference* anchors the iron and magnet assembly and the moving coil drives a free-piston *speaker cone* which is also supported by a *suspension spring* so that the coil stays centered in the gap and a *suspension damper* to limit the amplitude at resonance, when the acoustic loading is low. The speaker cone imposes an additional damping force based on the acoustic loading. More on that later.

Within the *transverse-coil actuator* submodel are these components representing the effective outer magnetic circuit consisting of the permanent magnet and iron:

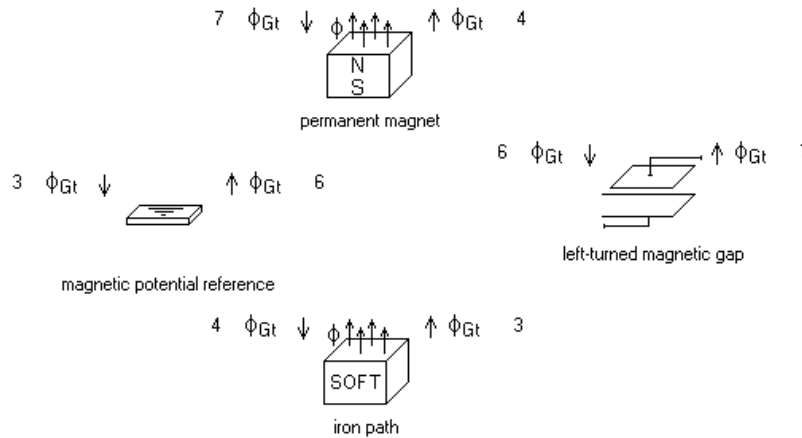

Inside the *left-turned magnetic gap* are *moving EM container* and *pole pair* components:



The voice-coil resides within the *moving EM container*:



The terminology *left-turned* and *left-turning* refers to the direction the inner pole piece directs the incoming magnetic flux from the outer pole piece. Which is the direction shown by the arrows in the above icon or in the negative x direction. This matters because the magnetic flux linked through the coil is the x-directed flux in the inner pole piece, which increases toward the negative x direction. This leads to asymmetries in the coil force with displacement giving the force a DC bias, even though the coil current may have no DC component.

There are also *right-turned* and *right-turning* magnetic gap and voice coil components available in Sage's component palette.

There are user-defined inputs defined in the *voice-coil actuator* submodel based on the symbols in the dimensioned picture below.

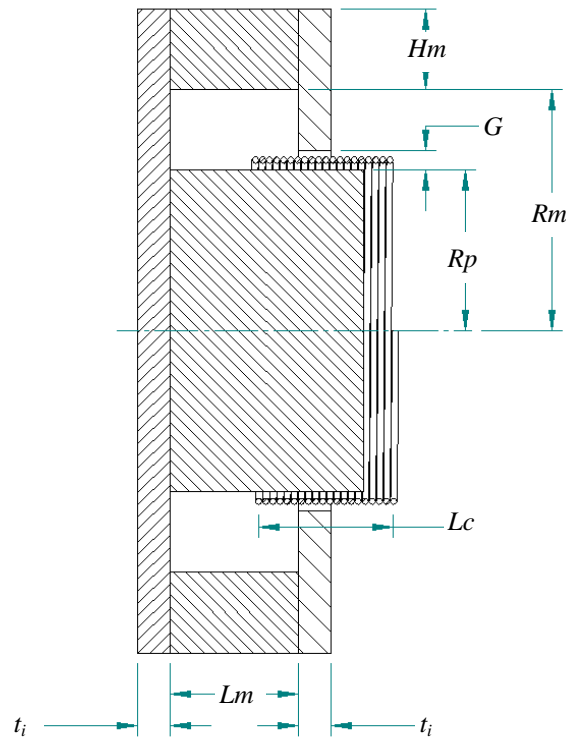

Inputs

Lmag	pole & magnet length (m)	2.000E-02
Rmag	magnet inner radius (m)	4.000E-02
Rpole	inner pole radius (m)	2.500E-02
Gap	air gap (m)	4.000E-03
Hmag	magnet radial height (m)	2.000E-02
thklron	iron thickness (m)	1.000E-02
Lcoil	coil outer length (m)	2.000E-02

User defined variables calculate the effective iron path area (cross section at the inner magnet radius), total iron path length and magnet cross section area as follows:

Outputs

Airon	iron path area	1.257E-03
	$\text{Pi} * \text{Rmag} * \text{thklron}$	
Liron	combined iron path length	5.850E-02
	$(\text{Rmag} - 0.5 * \text{Rpole}) + \text{Hmag} + (\text{Rmag} - (\text{Rpole} + \text{Gap}))$	
Amag	magnet cross section area	6.283E-03
	$\text{Pi} * (\text{Sqr}(\text{Rmag} + \text{Hmag}) - \text{Sqr}(\text{Rmag}))$	

The iron path area is taken as the iron circumferential section area at the inner pole radius R_p . The iron path length is the sum of three radial segments: in the back plate from $R_p/2$ to R_m , on the front plate from $R_p + G$ to R_m , plus two segments from R_m to magnet centroid of combined length H_m . The magnet cross section area is the true annular area.

In terms of the above, the inputs for a number of components are recast:

Iron Path Recasts

Lpath = Liron
Apath = Airon

Permanent Magnet Recasts

Lpath = Lmag
Apath = Amag

Left-turned Magnetic Gap Recasts

Zgap = Gap
Wpole = 2*Pi * (Rpole + 0.5*Gap)
Lpole1 = thklron

Moving EM Container Recasts

Length = Lcoil
Offset = -0.5*(Lcoil - thklron)

The *offset* defines the coil position within the air gap when the relative displacement of the *moving EM container* (output *Xrel*) is zero. The above value centers the coil in the gap at zero position.

In the left-turning voice coil the input that establishes the clearance between the wire and pole faces is

ZthkRel thickness fraction of parent Zgap [0, 1] 7.500E-01

Acoustical Loading

The speaker *cone component* connected to the voice coil (via force connection) is a reciprocating piston component with these inputs:

Inputs

Mass	reciprocating mass (kg)	1.500E-01
Dcone	cone diameter (m)	2.500E-01

The Mass represents the mass of the moving cone + coil, without the effective mass produced by the acoustic loading. Dcone is a user-defined input representing the effective diameter of the moving cone (diameter that displaces the same volume as the actual cone for a given displacement).

The forcing function input *FF* provides a way to include an external force in the reciprocating mass equation of motion (Newton's law $F = MA$). In this model that force is set to represent the acoustical loading on the cone.

Morse¹ provides an approximate expression for the acoustical impedance for the case of sound radiation from a piston in a wall (speaker enclosure). The impedance for a circular piston of radius *r* is written in the form

$$\frac{\mathbf{p}}{\mathbf{u}} = \rho c (R_a + iX_a)$$

p and **u** are the pressure and velocity phasors (complex amplitudes), ρc is the mean air density times the speed of sound. R_a and X_a are the resistive and inertial components of a complex factor that approach 1 and 0 respectively (impedance of traveling plane wave) for a speaker cone radius that is large compared to the wavelength. Otherwise Morse

¹ In, D.H. Menzel, *Fundamental Formulas of Physics*, Volume 1, Dover, (1960), p. 362

provides the following approximations in terms of the wave number $k=\omega/c$ (wavelength $\lambda=2\pi/k$).

$$R_a \approx \frac{1}{2}(kr)^2, \quad kr \ll 1$$

$$1, \quad kr \gg 1$$

$$X_a \approx \frac{8kr}{3\pi}, \quad kr \ll 1$$

$$\frac{2}{\pi kr}, \quad kr \gg 1$$

In terms of external force amplitude \mathbf{F} and cone area A the acoustical impedance may be written

$$\mathbf{F} = \rho c A (R_a + iX_a) \mathbf{u}$$

Where \mathbf{u} is the velocity phasor of the moving cone. Expanded in terms of velocity real and imaginary parts u_r and u_i the force amplitude is

$$\mathbf{F} = \rho c A ((R_a u_r + X_a u_i) + i(R_a u_i - X_a u_r))$$

So input FF is recast to:

FF = 0.000E+00...
 (-FFamp) Amp
 (FFarg) Arg

In other words the amplitude is recast to -FFamp and the phase to FFarg which are defined at the end of the following set of user-defined variables:

Acone	cone area	4.909E-02
	$0.25 * \text{Pi} * \text{Sqr}(\text{Dcone})$	
Csound	speed of sound	3.500E+02
	350	
RhoCair	Rho * C for air	4.025E+02
	$1.15 * \text{Csound}$	
kr	wave number * cone radius	2.244E-01
	$2 * \text{Pi} * \text{Freq} / \text{Csound} * 0.5 * \text{Dcone}$	
Ra	resistive impedance term	2.518E-02
	$\text{Min}(0.5 * \text{Sqr}(kr), 1)$	
Xa	inertial impedance term	1.905E-01
	$\text{Min}(8 * kr / (3 * \text{Pi}), 2 / (\text{Pi} * kr))$	
Ur	real part velocity	-1.723E+00
	$2 * \text{Pi} * \text{Freq} * \text{FX.Sin.1}$	
Ui	imaginary part velocity	-8.912E-01
	$2 * \text{Pi} * \text{Freq} * \text{FX.Cos.1}$	
FFr	real part acoustic force	-4.211E+00
	$\text{RhoCair} * \text{Acone} * (\text{Ra} * \text{Ur} + \text{Xa} * \text{Ui})$	
FFi	imaginary part acoustic force	6.040E+00
	$\text{RhoCair} * \text{Acone} * (\text{Ra} * \text{Ui} - \text{Xa} * \text{Ur})$	
FFamp	acoustic force amplitude	7.363E+00
	$\text{Sqrt}(\text{Sqr}(\text{FFr}) + \text{Sqr}(\text{FFi}))$	

FFarg	acoustic force phase	1.249E+02
	180/Pi * Arg(FFr, FFi)	
Wacoust	acoustical output power	9.358E-01
W.Mean		

How does the radiated acoustical power depend on frequency? According to the resistive impedance component R_a above, the acoustical loading imposes a dissipative force on the cone that in the limit of high frequency (plane wave impedance) is proportional to and in phase with the cone velocity, like a damper. At moderate frequencies ($kr < < 1$) the dissipative force is proportional to ω^2 . But the radiated power is proportional to the product of force and velocity amplitudes and the velocity amplitude is mainly determined by the inertia of the moving mass. This means that cone velocity amplitude tends to decrease in proportion to $1/\omega^2$ for a constant current amplitude (nearly constant coil force amplitude). The net result is that at moderate frequencies the radiated acoustical power (product of dissipative force and velocity amplitudes) is nearly independent of frequency, the holy grail of loudspeaker designers. At high frequencies the resistive impedance component R_a stops increasing and the radiated power drops off as $1/\omega^2$. This behavior can be seen in the plots below.

A different *spin* on the result of achieving frequency independent acoustical power is that it presents a loading on the coil that guarantees low electrical efficiency. This can also be seen in the plots below.

Energy Balance

It is helpful to consider the energy balance in the stationary parts separate from the moving coil. The following table accounts for the moving coil energy balance within the air gap for the model running at 100 Hz with current amplitude 5.0 amp.

	Power W
Input power from current source (Fwe)	-1.533E+02
Coil I^2R loss (Wdissip)	5.114E+01
Mechanical power output to suspension damper (W)	7.692E+01
Acoustical power output to speaker cone (W)	9.551E-01
Net power leaving air gap	-2.428E+01

This same power should be equal to the mean value for the FWm (magnetic power inflow) output for the pole pair component, which is **-2.410E+01**. The difference of about 0.2 W may be round-off error or a small numerical energy leak.

The next table accounts for the energy dissipation of that power in the stationary magnetic components.

	Power W
Iron path eddy-current loss (Weddy)	2.295E+01
Iron path hysteresis loss (Whyst)	1.149E+00
permanent magnet eddy-current loss (Weddy)	1.336E-04
Total losses	2.41E01

So energy is conserved within about 0.2 W.

The eddy current losses depend on the lamination thicknesses for the iron and magnet components. For loudspeaker actuators the time variation of magnetic flux in the iron and magnets is relatively low so there are no laminations per say. So the lamination thickness

inputs for the *iron path* is recast to t_i and the *permanent magnet* to W_m (in the above drawing) which are the minimum dimensions of the components when looking at a typical cross section normal to the magnetic flux direction. The $thkLam$ inputs are defined in the *object* components inside the *iron path* and *permanent magnet* components.

Electrical Impedance Map

The model is set up to map frequency (input *Freq*) over the range 20 to 2,000 Hz. The natural frequency of the *speaker cone + suspension spring* is **41 Hz** according to the formula

$$2\pi f = \omega = \sqrt{K/M}$$

The cone mass is $M = 0.15$ kg and spring stiffness is $K = 1.0E4$ N/m.

Of interest to loudspeaker designers is the electrical impedance at the coil terminals defined as

$$\mathbf{Z} = \frac{\mathbf{V}}{\mathbf{I}}$$

Where \mathbf{V} and \mathbf{I} are voltage and current phasors. Electrical impedance is a combination of coil resistance and inductance complicated by the reflection of the cone dynamic response into the coil voltage and current. The amplitude of \mathbf{Z} is V_1/I_1 where V_1 and I_1 are the voltage and current amplitudes and the phase is the difference between voltage and current phases. The model calculates electrical impedance via these user-defined variables of the *current source* component:

Zamp	electrical impedance amplitude	1.435E+01
FDeltaV.Amp.1 / FI.Amp.1		
Zarg	electrical impedance phase	-3.157E+01
FDeltaV.Arg.1 - FI.Arg.1		

When mapped over a frequency range the model produces this electrical impedance curve:

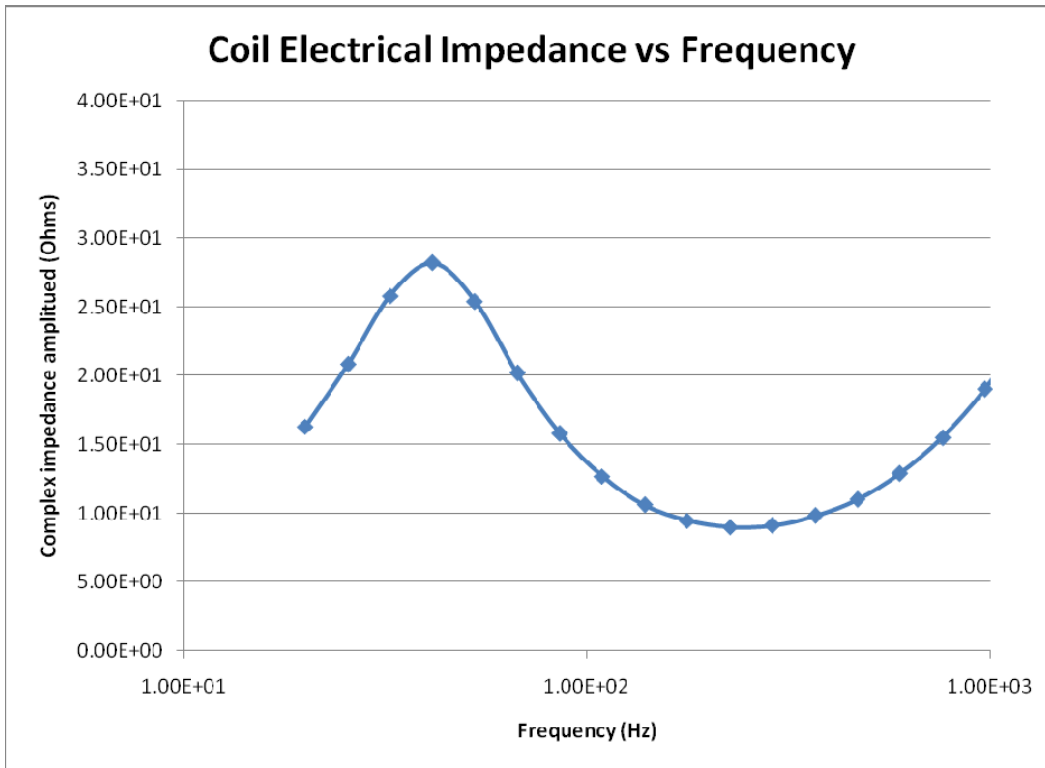

According to Wikipedia² the nominal impedance of a loudspeaker is 1.15 time higher than the minimum impedance along the frequency curve. So the loudspeaker in the model has a nominal impedance of about 10.4 ohms (minimum impedance 9.0 ohms).

To produce the impedance map it was helpful to temporarily reduce the current amplitude to 0.5 amp.

² http://en.wikipedia.org/wiki/Electrical_characteristics_of_dynamic_loudspeakers

Radiated Acoustical Power

The plot below shows the *speaker cone* acoustical power output for a constant current amplitude of 0.5 amp.

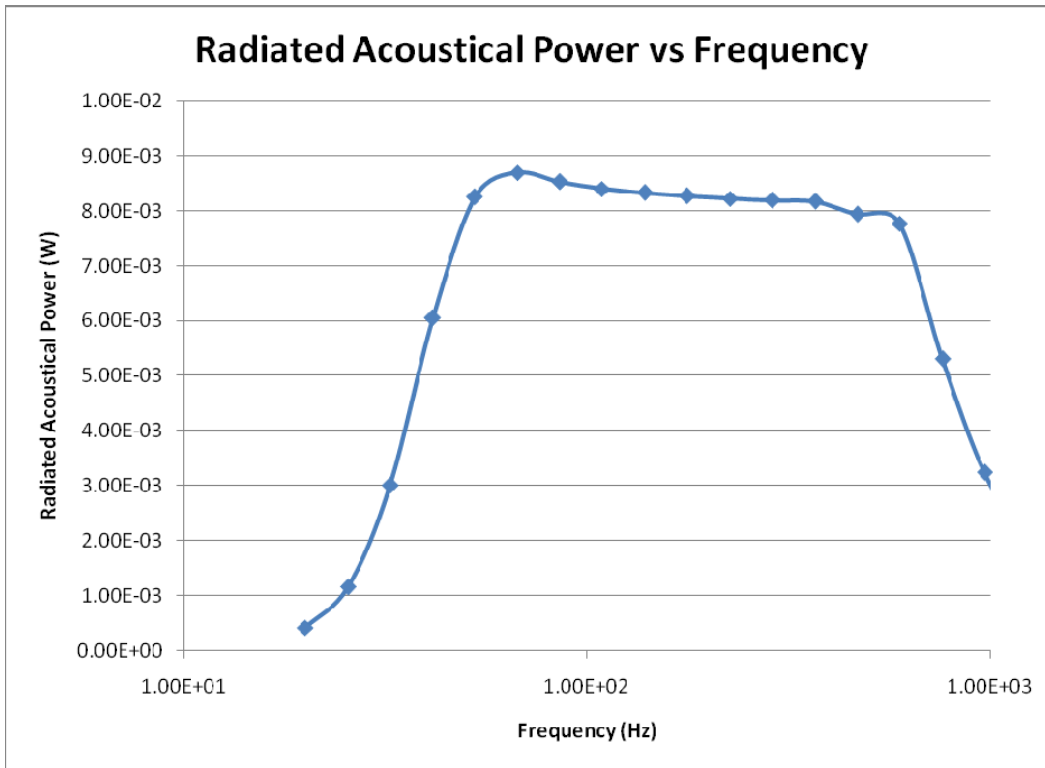

A sharp peak at the 41 Hz mechanical resonant frequency is eliminated by choice of the damping coefficient (40 N s/m) of the *suspension damper* component. That is about half the critical damping ratio of 77 Ns/m, given by the standard formula

$$D_c = 2\sqrt{MK}$$

The level area between 80 Hz and about 800 Hz is the desirable loudspeaker behavior where the resistive impedance component R_a is growing as the square of frequency, as discussed above. The high frequency drop-off is where $R_a = 1$. The transition is more abrupt than would actually be the case because of the two-part approximation used to calculate R_a (*speaker cone* user variable R_a above)

Efficiency

The loudspeaker electrical efficiency can be seen in this plot:

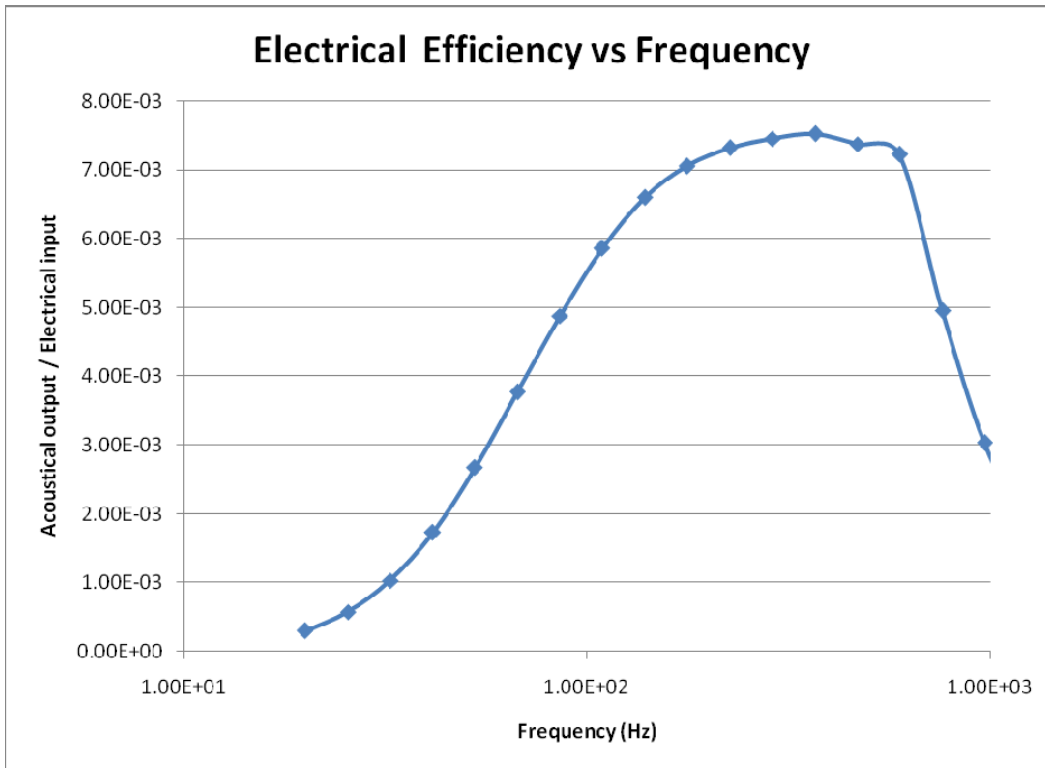

Electrical efficiency is defined as time-average electrical input power / acoustical power output, which is available in the model via user-defined variables *Wacous* in the *speaker cone*, *Welec* in the *current source* and *Effic* in the root model. The peak efficiency is about 0.75% at about 400 Hz.

The efficiency is necessarily low because of the behavior of the acoustical loading. If the voice coil were loaded by a simple damper and driven at its resonant frequency the efficiency would be much higher.

Looking at it another way, the efficiency is low because the electromagnetic dissipations (mainly the coil resistance dissipation) are relatively constant but the radiated power is very low.

Solution Grid

You can understand more about the model by dumping the solution grid for the two-pole magnetic gap component, which contains the grids for the moving EM container, the voice coil, the coil object and the pole pair.

For example, the plot below shows the linear magnetic flux distribution in the coil-relative reference frame at various times as it moves through the magnetic gap.

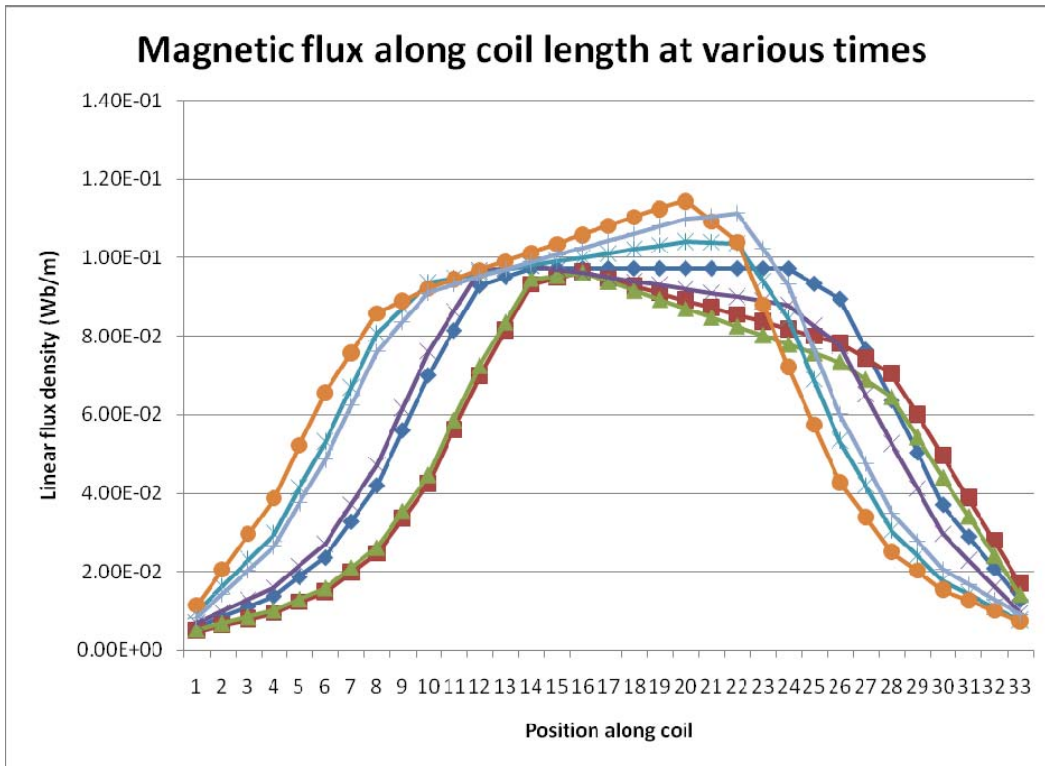

The magnetic flux is highest for the part of the coil between the pole faces and drops off on either side according to the fringing flux formulation in Sage. The reason the location of the highest magnetic flux moves back and forth is because the plot is in the coil reference frame from which the outer magnetic structure appears to be moving back and forth.

The effect of the coil electrical current shows up in the sloping magnetic flux for the part of the coil between the pole faces. When the current is zero (dark blue curve) the magnetic flux is produced solely by the permanent magnet and is uniform along the pole faces. When current is not zero it produces a magnetic potential difference that increases in magnitude from zero at the left (negative) end of the coil to a maximum at the right end and beyond. This drives a sloped magnetic flux along the pole faces, either upward or downward depending on the direction of the current (magnetic potential difference).