

# Sage Model Notes

## Transformer.scfn

D. Gedeon

3 June 2012 (revised 1 November 20224)

A model of transformer consisting of two coils wound around a rectangular core in the standard fashion:

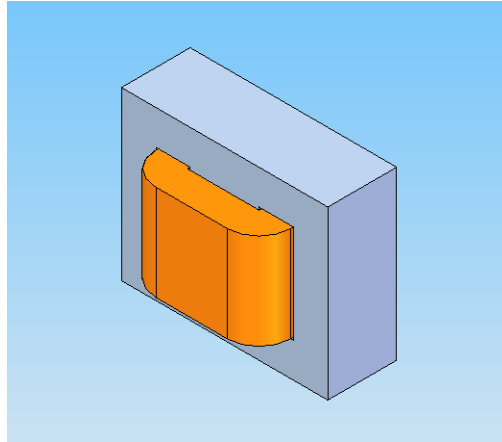

The Sage model looks like this:

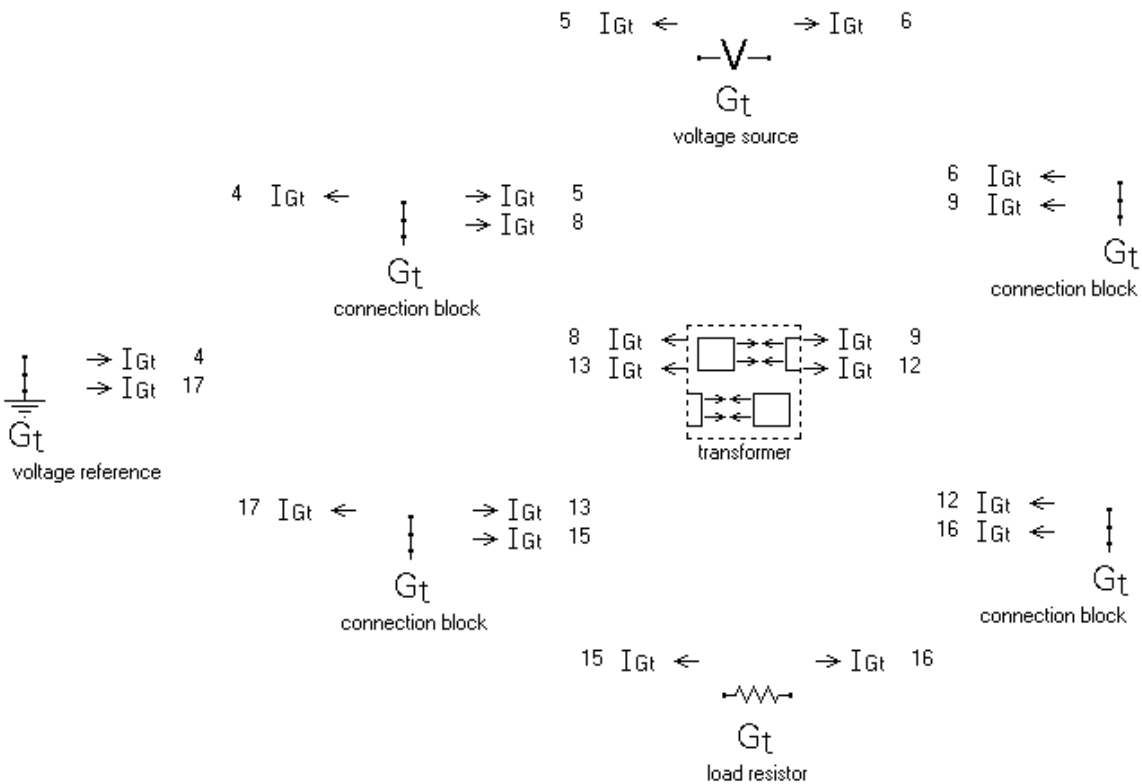

A voltage source (top row) drives electrical current through the primary winding within the transformer submodel. The secondary winding drives current through the load resistor. Within the transformer submodel are these components:

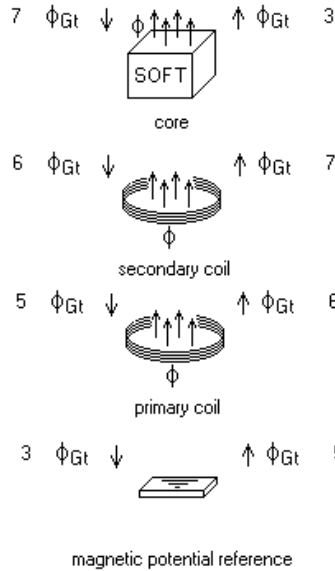

The two coils and core (ferromagnetic material) form a magnetic circuit anchored by a magnetic potential reference. Electrical current flowing through the primary coil produces a magnetic field that drives magnetic flux through the secondary coil. Actually, both coils produce magnetic fields that combine to produce magnetic flux through the core that links both coils.

In a real transformer the core is not the one dimensional rectangular solid of the Sage model. Viewed from the side and end it typically looks something like this:

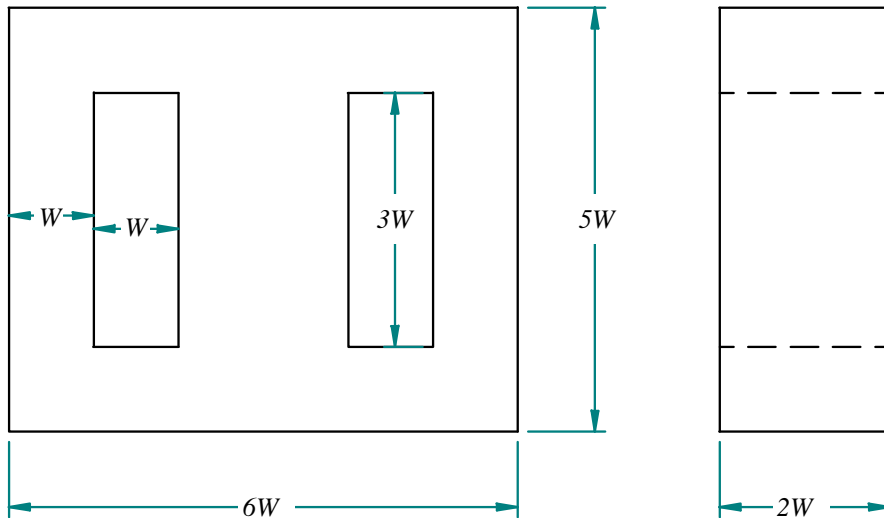

The coils are wound through the rectangular cutouts. Fluctuating current in the coils drive magnetic flux up (or down) the central leg where it splits to form two loops directed down (or up) the outer legs and returning to the central leg. In the Sage model these two flux loops are combined into a single one-dimensional path of cross-section area equal to the central leg cross section and length equal to the mean length of the path around one of the cutouts.

For simplicity all core dimensions are multiples of the leg width  $W$ , which is user-defined variable  $W_{leg}$  in the transformer submodel. It would be possible to revise the model so that core thickness and dimensions of the rectangular holes where the coil fits are independent inputs. But in any case the width of the outer, upper and lower legs should all be half the central core width to maintain uniformity of flux path area.

The flux path cross section area is  $A_{path} = 4 W^2$  and the length is  $L_{path} = 12 W$ , which is the path length along the leg center axes. The inputs for the core model component are recast to these values.

Viewing the transformer from above the coil centroid perimeter is evidently  $12 W$ . So for both primary and secondary coils the  $D_{centroid}$  inputs are recast to the diameter of the circle with the same perimeter  $12 W/\pi$ .

The primary and secondary wire diameters are recast so that the coil fits into the core cutouts. The total coil cross section area must be  $A_{cutout} = 3 W^2$ . Assuming primary and secondary windings have the same cross section then each has a cross section area half that, which establishes the cross section area of an individual wire as

$$A_w = \frac{\alpha A_{cutout}}{2N}$$

Where  $\alpha$  is the coil packing factor and  $N$  is the number of turns. The wire diameter must then be

$$D_w = \sqrt{\frac{4}{\pi} A_w}$$

## Transformer Theory

Faraday tells us that the induced voltage drop in the primary coil (subscript 1) is

$$\Delta V_1 = N_1 \frac{d\phi}{dt}$$

Where  $N_1$  is the number of turns in the winding and  $d\phi/dt$  is the change in magnetic flux linked through the coil. Likewise for the secondary coil

$$\Delta V_2 = N_2 \frac{d\phi}{dt}$$

Since the  $d\phi/dt$  factors are the same for both coils it follows after eliminating  $d\phi/dt$  that

$$\frac{\Delta V_2}{\Delta V_1} = \frac{N_2}{N_1}$$

Voltage drops  $\Delta V_1$  and  $\Delta V_2$  are the open-circuit voltages. In reality each is reduced by the voltage drop due to electrical resistance  $IR$ . The Sage model defines user variables  $DV_{indAmp}$  which add the  $IR$  component back into the net voltage difference amplitude across the coil to obtain the components due to induction. The ratio of the  $DV_{indAmp}$

values for the secondary and primary coils satisfies the ideal transformer relationship above.

## Energy Conservation

In a real transformer as well as the Sage model there are losses in the coils and core that reduce the transformer electrical power output relative to the electrical power input. In a real transformer the difference between input and output power equals the sum of the losses. This should also be true, or close to true, in the Sage model but it pays to check.

The following values come directly from the Sage model:

	Power in W
Input power from voltage source	73.06
Output power to load resistor	67.38
<b>Difference</b>	<b>5.68</b>
Primary coil $I^2R$ loss	2.616
Secondary coil $I^2R$ loss	2.578
Core eddy current loss	0.378
Core hysteresis loss	0.114
<b>Total</b>	<b>5.686</b>

So the Sage model conserves energy.

## Eddy Current Loss

The core material is grain-oriented silicone steel which is an electrical conductor so the changing magnetic flux through the core induces eddy currents. The eddy current loss is strongly dependent on the lamination thickness, which is defined by input

ThkLam      lamination thickness (m)      5.000E-04

of the soft ferromagnetic object in the coil. For this lamination thickness the eddy current loss is only 0.379 W for the particular example in the above table. But eddy current loss grows as the square of lamination thickness so the loss can get large quickly for thick laminations. Beware.